

# KOPF®

Precision Designs for Research



Model 720 Needle Pipette Puller  
Instruction Manual



## CAUTION

- 1) **READ** instruction manual completely prior to operating unit and note operating voltages!
- 2) **DO NOT** turn on with voltage set high as it may destroy the platinum alloy filament!
- 3) **DO NOT** cut string between solenoid plunger and slide assembly!

## Table of Contents

Page

<b>CAUTION</b> .....	2
Introduction .....	4
Pipette Nomenclature .....	4
Factors Affecting Pipette Shape .....	4
A. Other factors .....	5
B. Glass .....	5
C. Heater Filaments .....	6
D. Solenoid force .....	7
Reproducibility .....	7
Controls and Indicators .....	8
Instructions for use .....	8
Care and Maintenance .....	12
New Pad Installation .....	12
Specifications .....	13
Voltage Selection & Fuse Changing .....	14
Standard Accessories .....	15
Optional Accessories .....	15
SHIPMENT .....	16
PACKING .....	16
PULLER PACKAGING .....	17
RETURNED GOODS .....	18
IMPORTANT NOTICE FOR RETURNED GOODS .....	18
WARRANTY AND DISCLAIMER .....	19

## ***Introduction***

The **Model 720** Needle/Pipette Puller (Single Stage) is the ideal instrument for the busy laboratory where a number of pipettes are required. This unit is easy to use, versatile and a reliable vertical pipette puller with excellent repeatability.

Controllable parameters include heater voltage, solenoid current and length of gravity fall. These parameters coupled with heater configuration allow a wide variety of pipettes to be pulled.

Large tips as well as tips of 0.25 microns or less can be obtained. Pipette glass diameters of 0.4 mm to 3.0 mm, thin as well as heavy walled, can be held and pulled.

The unit pulls pipettes vertically to help assure straight, concentric shapes. In addition, its small, compact size (11" x 9-1/2" x 14-1/2") occupies less than a square foot of bench space. Like all Kopf instruments, the Model 720 is built for reliability and durability and requires little maintenance. The slide mechanism employed is a super accurate component that has been used for more than 35 years on other Kopf vertical pipette pullers.

## ***Pipette Nomenclature***

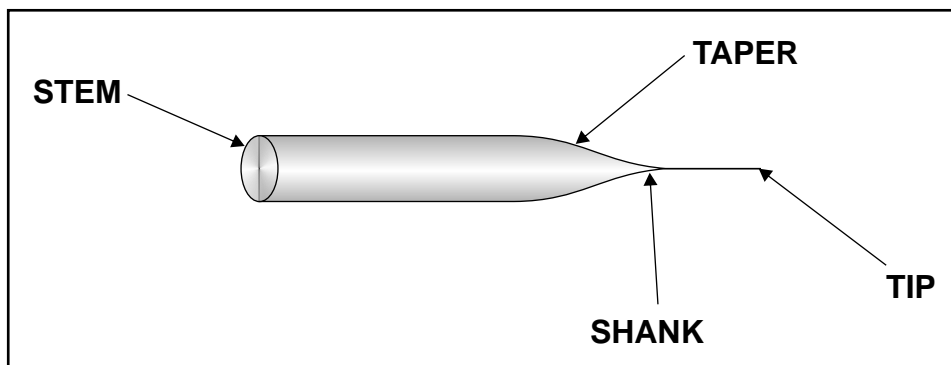

## ***Factors Affecting Pipette Shape***

Obtaining acceptable tapers on micropipettes depends on the following: Placement of the glass within the filament, temperature of the filament and the strength and length of the pull.

### ***A. Other factors which can affect reproducibility are:***

1. Shape distortion (out of round tubing)
2. Oxidation (heat capacity) of heater filament
3. Proper alignment of heater filaments
4. Proximity of heater filaments to the tubing
5. The presence of dirt on the glass
6. The presence of dirt on the filament
7. Alignment of tubing on the puller assembly
8. Sudden change in currents of air and temperature changes
9. Experience of the operator

### ***B. Glass***

The diameter of the glass and wall thickness (O.D. / I.D.) will change the pull time. A change as small as .04 mm O.D. can result in as much as a second difference in pull time. Variations of more than .04 mm O.D. in a single piece of glass have been measured as an out of round condition. Glass within the same batch can vary by more than .08 mm. These variations will affect the pull time and consequently the shape of the pipette.

Soda lime glasses containing Na<sub>2</sub>O have a low heat resistance, a less than desirable chemical stability, and higher conductivity than borosilicate glasses. Lead glasses containing PbO have good hot flow characteristics and high electrical resistivity. They have a high thermal coefficient, however, and produce a fragile shank and tip. The borosilicate glasses such as Pyrex, Kymax and Phoenix brands have produced very satisfactory micropipettes. They have a low coefficient of thermal expansion, high resistance to heat shock, high chemical stability and excellent electrical resistivity. Aluminosilicate glass has also been used to make pipettes; it is harder than borosilicate glass. A glass-tubing diameter of 3.0 mm is the maximum which can be pulled successfully with a single pull with the Model 720. Tubes with a filament running down the inner wall to facilitate filling of the microelectrode tip by promoting capillary action; "Theta" and Quad" capillary tubing, created by internal dividing walls, are available commercially.

By setting or adjusting values for the various parameters in a pulling sequence you can vary the length, taper and tip to achieve an almost endless variety of shapes and sizes. Like many laboratory instruments, proficiency of use depends upon the skill and experience of the operator. You can expect to become proficient within a minimum amount of time.

Some sources of glass are: A & M Systems, Harvard Apparatus, Holliston, Massachusetts; Corning Glass Works, Corning, NY; Frederick & Dimmock, Melleville, NJ; Glass of America, Bargaintown, NJ, Kimble Products, Vineland, NJ. We suggest starting with a type of glass used by one of your colleagues for your application.

### ***C. Heater Filaments***

Heater filaments variables are temperature, shape and proximity to the glass. Heat and its distribution along the glass influence pulling time. The higher the temperature, the longer the pipette. Two sizes (1.5 mm and 3.0 mm) of 90% platinum/10% iridium heater filaments and a standard 2.5 turn nichrome heater coil are included as part of the 720 puller package. See Page (16) for other optional heater filaments and order information. Other coils with 1½, 3½, or 4½ turns are available on request.

The melting point of nichrome is approximately 1400°C; platinum/iridium is approximately 1800°C.

#### **Platinum/Iridium Heater Filaments - vs - Coils**

The major control factor in forming pipettes is heat. It is easier to control the heating of a pipette with a ribbon filament than with a heater coil. One end of the coil has approximately 180° more coil than the other end thereby resulting in uneven heating of the pipette.

A ribbon filament will allow you to form a glass pipette at a lower current and will result in more concentric heating of the pipette.

Two conditions that affect the pipette are the width of the filament and the proximity of the filament to the pipette. A wide element gives a longer taper than the narrow element.

The "U" of the filament needs to be deep enough to allow even heating of the glass (approximately 10 mm deep). The glass should be positioned approximately 1/3 of the way into the loop and equidistant between the sides of the filament. This position will keep the high heat area of the filament curve away from the pipette and allow even heating from the filament sides.

Lower current and longer pulling solenoid time (or gravity fall) gives more consistent results (see page 7, Fig. 2).

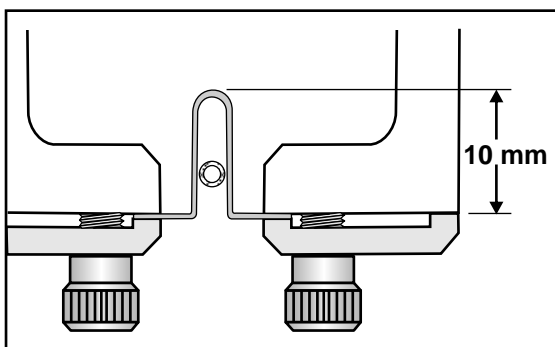

Figure 2. Drawing of Pipette Placement in Platinum Filament shown in Heater Bracket Model 726.



Figure 2A. Model 726 Heater Bracket

**CAUTION: THIS UNIT IS POWERFUL ENOUGH TO MELT THESE FILAMENTS (SEE INSTRUCTIONS PAGE 9, ITEM 11).**

### ***D. Solenoid force***

The force applied in separating the pipettes plays a major role in their shape, particularly during the draw. A repeatable pull is necessary to make good pipettes. When the glass reaches a viscous state, the initial pull is first determined by gravity. As the slide falls a preset distance, an optical switch is activated turning off the heater and turning on the solenoid for the final pull. The shape of the pipette may be changed by varying the distance at which the solenoid is activated and the pulling force of the solenoid.

### ***Reproducibility***

The Model 720 will repeatedly pull micropipettes of the configuration for which it has been set. This is possible because of the ability to control the parameters in the pulling sequence and the superb accuracy of the vertical slide mechanism. Small fluctuations in heater temperature can significantly affect the shape of a pipette during the pulling sequence. To help prevent this, the Model 720 is designed to be less susceptible to line voltage changes and therefore provides superior heat regulation. For maximum reproducibility, turn the unit on for a 30-minute warm-up before using. Another factor, which can adversely affect pipette shape, is residual heat. The 720 helps to eliminate this problem in several ways. The heater turns off the instant the solenoid is activated and since the unit is of vertical design, any residual heat rises up away from the tips. The use of platinum / iridium filaments further minimize the problem since the filaments have an extremely low thermal mass and cool very rapidly. Both tips are below the heater filament when the pull is complete.



## ***Controls and Indicators***

1. **ON/OFF** Switch. The power switch is located on the back.
2. **POWER** Light. Is on when the main power switch is on.
3. **OPTICAL SWITCH WITH ADJUSTABLE FLAGS**. The optical switch is pre-set at the factory for approximately 2.5 mm "gravity fall" before heat is turned off and "solenoid pull" is affected.
4. **HEATER** Knob. Used in conjunction with the digital display to control the power voltage being delivered.
5. **HEATER** Digital Display. Three digit display allows power being delivered to the heater to be adjusted to tenths.
6. **SOLENOID** Knob. Controls the current delivered to the solenoid, which determines the force of the final pull.
7. **START** Button. Energizes the heater to start a pulling sequence.
8. **READY** Light. Indicates the unit is ready for a pulling sequence.

## ***Instructions for use***

1. Place the puller in a location, which is level and free of drafts and sudden temperature changes. **DO NOT PLACE ON FOAM OR OTHER SOFT MATERIAL AS AIR VENTS ARE LOCATED ON THE BOTTOM OF THE UNIT.**
2. Check to see if the power entry module, located in the back panel, is set for the proper voltage.
3. Insert plug-in heater bracket and filaments.
4. Turn power on. On/ Off switch on rear panel. Power light indicator on front of the puller should go on.
5. Feed glass tubing through the upper clamp and the heater until about half of the tubing extends below the heater coil or heater filament. Make sure tubing is in the "V" groove in the upper clamp. Tighten the upper clamp screw finger tight.

6. Check to see that the heater coil or heater filament and the glass tubing are properly aligned. The coil or filament and the tubing should be concentric. Lateral adjustment can be made to the coils by loosening the two knurled nuts, which hold the coil; make sure these nuts are tight before using the puller. **DO NOT ADJUST** by moving plug in the holder in, out, or side ways (see page 7 fig. 2) for proper adjustment of the platinum / iridium filaments.
7. Make sure the lower clamp is open. Bring the vertical slide up until the lower clamp reaches its upper limit. Make sure tubing is in "V" groove in lower clamp. Tighten the lower clamp screw finger tight.
8. To set the **OPTICAL SWITCH** operating point to your own requirements:
  - a. Lower the upper flag approximately 6 mm by loosening Allen set screw "A" in flag, lowering flag and tightening set screw.
  - b. Set the amount of "Gravity Fall" by raising the "Slide Assembly" up against a "Space Block" equal to the amount of "Gravity Fall" you require (see page. 11, Fig. 4 ). Loosen set screw "B" and adjust top edge of lower flag slightly to engage the ready light "On". Then tighten set screw "B". Be sure that the lower flag freely passes through the optical switch when the slide is lowered.
  - c. Reposition the upper flag against the upper clamp bracket by loosening the set screw raising the flag and tightening the set screw. Again make sure that both lags pass freely through the optical switch, adjust positions if necessary to accomplish this.
  - d. The upper flag must be in the optical switch so that the ready light is on when the slide is in the down position. This will allow you to adjust the heat setting. After the heat is adjusted, a quick raising and lowering of the slide will turn the heat "off" and turn the ready light back "on" so that you are ready to start pulling pipettes at this new setting.
10. Set the **SOLENOID** Control Knob.
11. Set **HEATER** Control Knob, starting at **FULL COUNTERCLOCKWISE POSITION**, for desired setting of digital display for chosen element type (see page 10, Fig 3). The 3 mm platinum alloy filament requires a higher heat setting than the 1.5 mm platinum alloy. The nichrome coil requires an even higher setting. Platinum alloy filaments heat instantly while it takes several seconds for nichrome coils to heat. **THIS UNIT IS POWERFUL ENOUGH TO MELT THESE FILAMENTS.**

12. **READY** Light should be on. Push **START** button to initiate the pulling sequence.
13. As the glass tubing becomes viscous the gravitational force of the slide will initiate a downward pull.
14. At a pre-set distance of fall, the optical switch is activated, the heater turned off and the solenoid is activated to complete the pull.

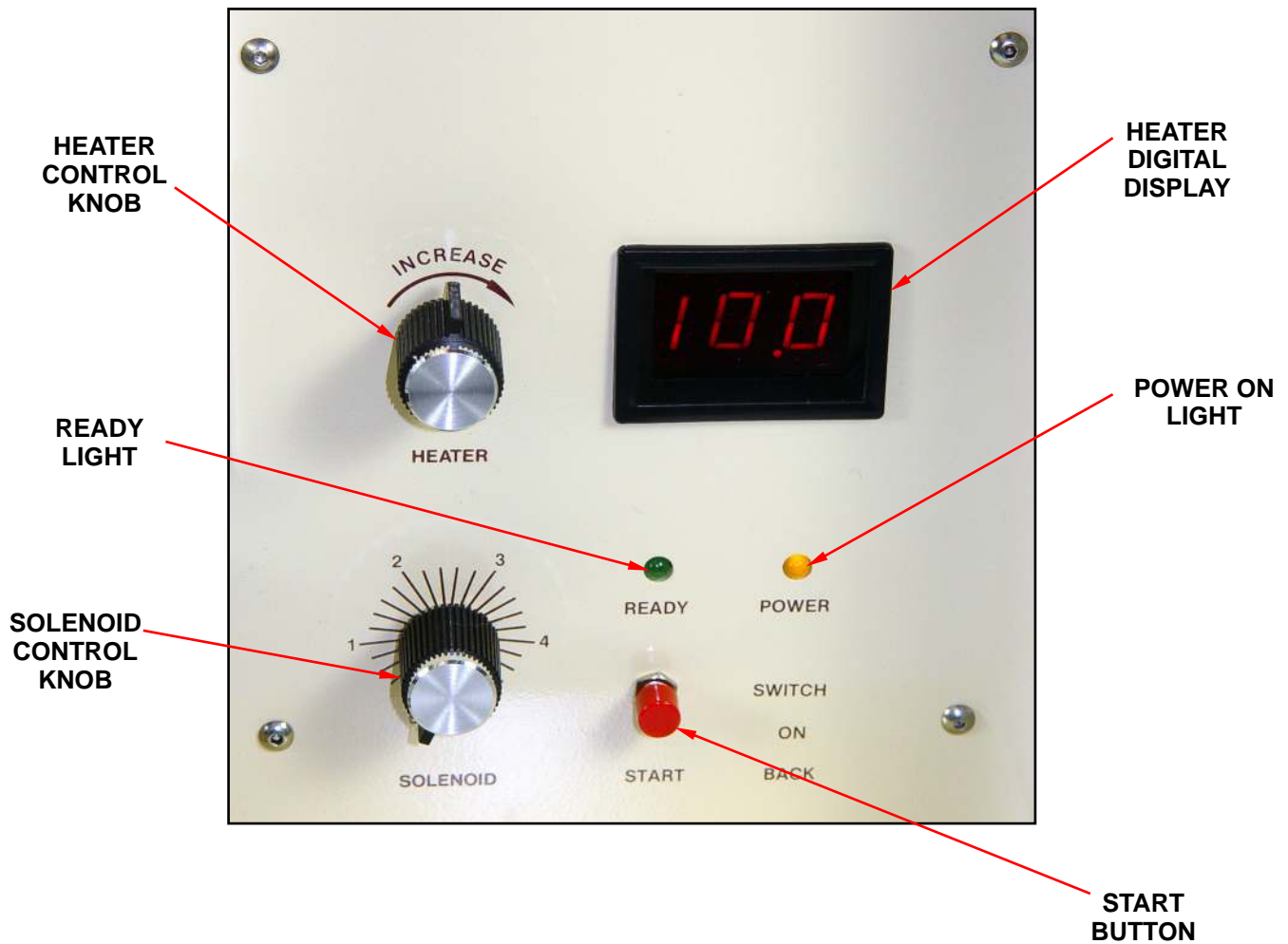

**Figure 3**

**720 Slide Assembly**

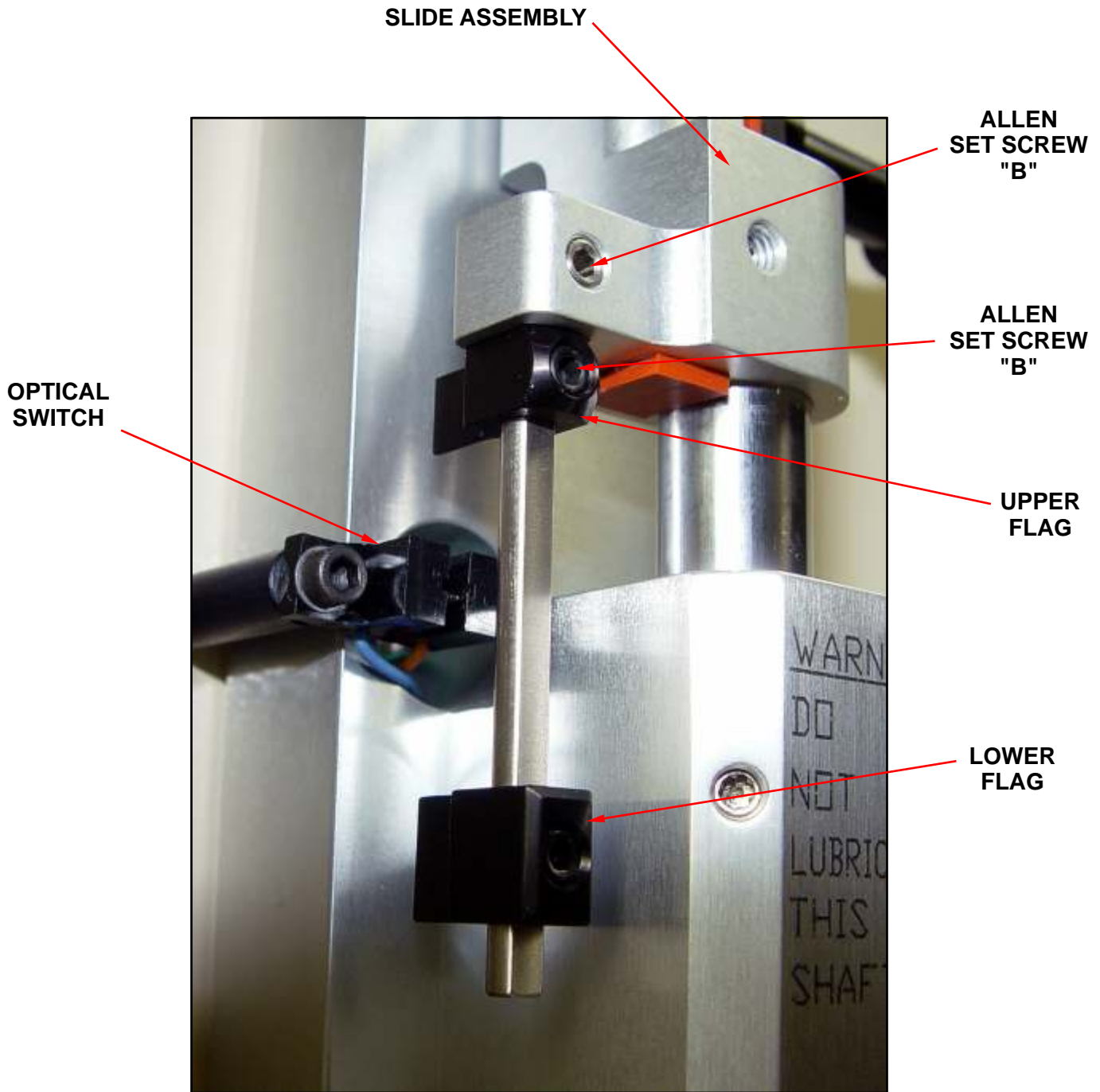

**Figure 4**

## Care and Maintenance

Like all Kopf instruments, the Model 720 is built for reliability and durability and requires little maintenance.

1. Vertical slide must be kept clean. Clean with alcohol. **DO NOT OIL.**
2. If glass falls through the slide onto the bottom of the unit, you can remove the two allen screws holding the solenoid cover to the base to clean it out.

As in other fine pieces of equipment, normal care and maintenance should be followed

- ✦ **Do Not** lubricate vertical slide shaft.
- ✦ **Do Not** drop any portion of the apparatus as this may seriously disturb the calibration.
- ✦ **Do Not** allow the instrument to accumulate blood, hair, dust, or other matter as this will disrupt movement and accuracy
- ✦ **Do** clean instrument with mild soap or zephirin.
- ✦ **Do** store in dust free areas.

## Installation of New Pads

1. Remove from pipette puller (part # 750-GG Clamp & Pad)
2. Remove screws (750-17) and spring (8147).
3. Use single edge blade and scrape off all the old glue left on the metal clamp. Do not worry if some black anodize comes off.
4. Clean the bonding area with non oily solvent (such as isopropyl alcohol).
5. Take new rubber pads (750-29) and remove glaze from one side (to be bonded). Use fine (400 - 600 grit) sandpaper and clean with solvent. Use cotton swab (0-tip).
6. Apply a small drop of glue (all purpose instant adhesive) on the rubber pad and spread with paper clip or equivalent.
7. Take the metal part and press down to the glued side of the rubber pad and be sure it is even with the edge. Support opposite end of black metal clamp to keep level while glue sets. Use cotton swab (Q tip) to remove any excess glue from the front edge. Apply pressure for approximately 15 seconds.

Let set overnight for best results.

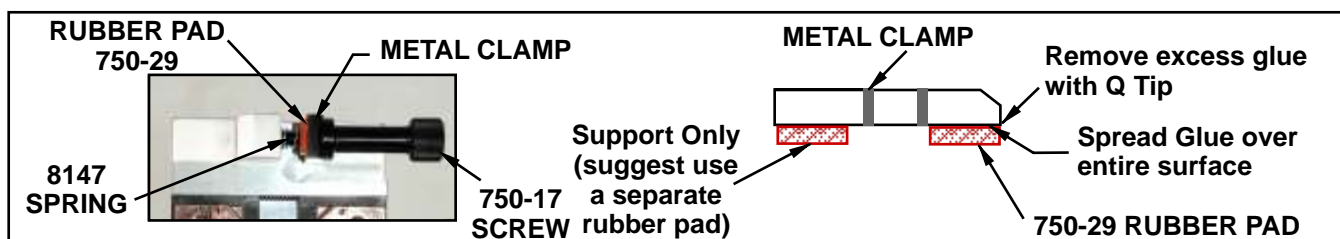

## Specifications

Size:	11"D x 9½"W x 14½"H
Weight:	29 pounds, 10 ounces
Input Power:	100/120/220/240 VAC, 50-60 Hz, via rear panel adjustable power entry module (comes with appropriate power cord).
Digital Display:	Three digits, adjustable to tenths
Heater Voltage:	0-19.5 units with resolution of 0.1.
Solenoid Current:	0-5 amps DC regulated.
Optical Switch:	Fixed location with adjustable flags.
Fuses:	4 amp (100/120 VAC); 2.15 amp (220/240 VAC); 1.5 amp (11 VAC)



With the exception of accessories itemized on page 15, which may be replaced by customer. All components including electronics are repairable by manufacturer only. Any attempt to service or repair unit will void manufacturer's warranty. **DO NOT OPEN UNIT.**

## Voltage Selection

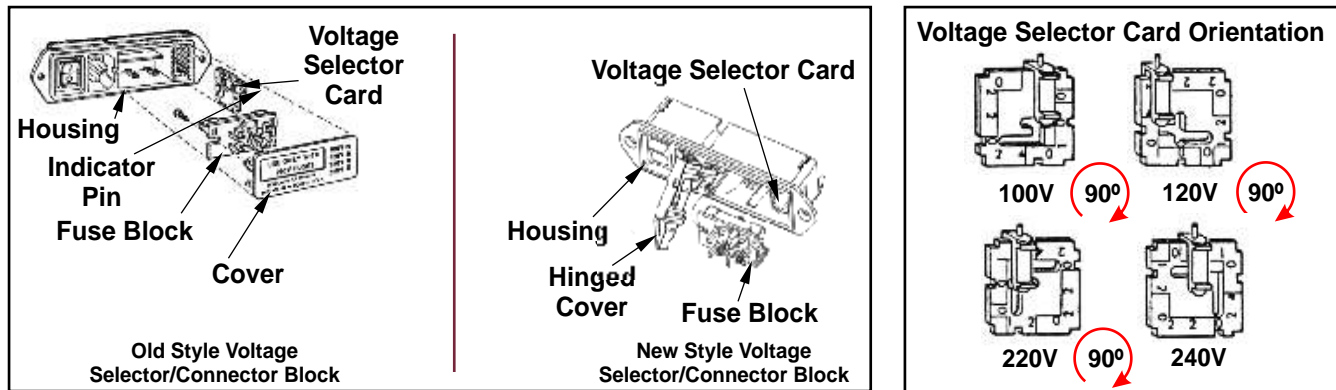

1. **To Change Selected Voltage:** Open **Cover**, using small blade screwdriver or similar tool; set aside **Cover/Fuse Block Assembly**. On new style housing open with small blade screwdriver and swing **Hinged Cover** open.
2. Remove **Fuse Block** and set aside.
3. Pull **Voltage Selector Card** straight out of housing, using **Indicator Pin**, orient **Selector Card** so that desired voltage is readable at the bottom. Orient **Indicator Pin** to point up when desired voltage is readable at bottom (note that when **Indicator Pin** is fixed, successive voltages are selected by rotating the card 90° clockwise).
4. Insert **Voltage Selector Card** into housing, *printed side of card facing toward IEC connector*, and edge containing the desired voltage first.
5. Replace **Cover**, and verify that **Indicator Pin** shows the desired voltage. On new style **Hinged Cover** swing and snap closed.

## Fuse Changing

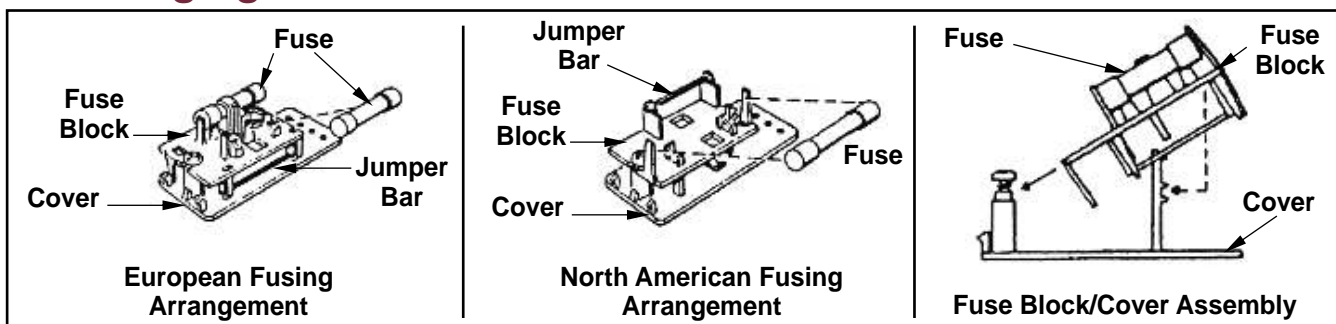

### To Change from North American to European Fusing on old style Fuse Block:

1. Open **Cover** using small blade screwdriver or similar tool.
2. Loosen Phillips screw 2 turns.
3. Remove **Fuse Block** by sliding up, then away from Phillips screw and lifting up from pedestal.
4. Change fuses (note that two **European Fuses** are required, although a dummy **Fuse** may be used in the neutral (lower) holder).
5. Invert **Fuse Block** and slide back onto Phillips screw and pedestal.
6. Tighten Phillips screw and replace **Cover** (note that **Fuse(s)** that go into the housing first are the active set).

### To Change from North American to European Fusing on new style Fuse Block:

Since there is no screw to remove or loosen on the new style block simply change fuses as shown from North American to European configurations.

## Standard Accessories

- Plug-in Coil Bracket, Model 725
- One Standard 2½ turn Nichrome Heater Coil, Model 710.
- Two Platinum/Iridium Heater Filaments: One 715-16 (1.5 mm) and one 715-31 (3 mm) (preformed)
- Fuses: One complete replacement set.
- Pads for upper and lower clamps (may be attached by using Eastman 910 type glue i.e., super glue)
- Allen Wrench for Optical Switch and Solenoid Rod.

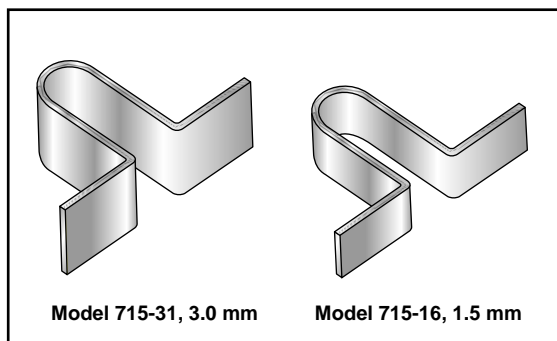

**Model 715 Standard Preformed Platinum Alloy Filaments**

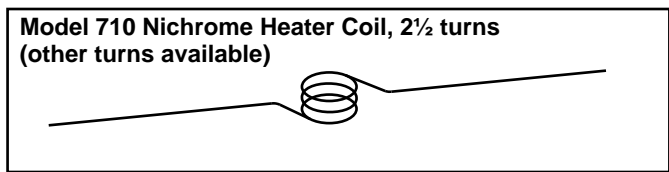

## Optional Accessories

- **Model 710** Nichrome Heater Coil with standard 2½ turns for replacement, 1½, 3½ or 4½ turn Nichrome Heater Coils available upon special request.
- 90% Platinum/10% Iridium Heater Filaments  
**Model 715-16** 1.5 mm Heater Filaments, Preformed  
**Model 715-31** 3.0 mm Heater Filaments, Preformed.
- Platinum Omega Filaments  
**Model 727-16** 1.5 mm Omega Heater Filaments, Preformed  
**Model 727-31** 3.00 mm Omega Heater Filaments, Preformed

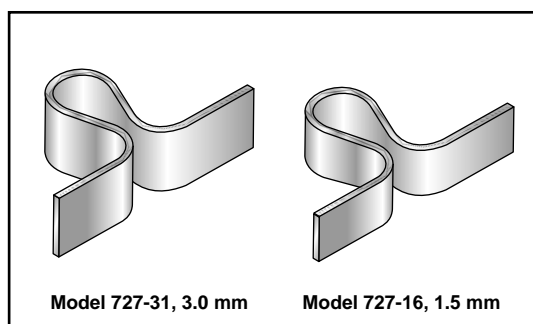

**Model 727 Standard Preformed Platinum Omega Filaments**

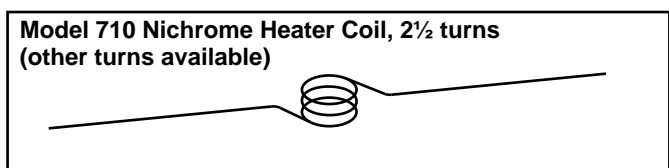



## ***Shipment***

Whenever possible United Parcel Service will be used. Otherwise, air freight or air parcel post will apply unless specified to the contrary. No C.O.D. shipments will be made or accepted without prior authorization. All shipments will be insured and the cost included in the freight charges to the customer unless directed to the contrary.

**Products should be inspected upon receipt and checked against the enclosed packing list. Any irregularities must be reported to the Customer Service Department of David Kopf Instruments within 15 days of receipt of order.**

The Interstate Commerce Commission has held that the carrier is as responsible for concealed damage as for visible damage in transit. If damage is discovered, cease further unpacking and request immediate inspection by the local agent of the carrier. The request must be made within 15 days of receipt, or the carrier will not honor the claim. **DO NOT** return damaged goods to the factory without first securing an inspection report.

After damage inspection report has been secured, David Kopf Instruments will cooperate fully in shipping replacements and in handling the claim initiated by either party.

## ***Packing***

With the exception of very small items all instruments are packaged in cartons. Adequate padding is used to insure safe arrival of the equipment at its destination.

**Keep all packaging materials and carton in the event the unit is to be returned to factory for any reason.**

## Puller Packaging

To insure equipment safety during transit we have outlined below the proper procedure for packing instrumentation.

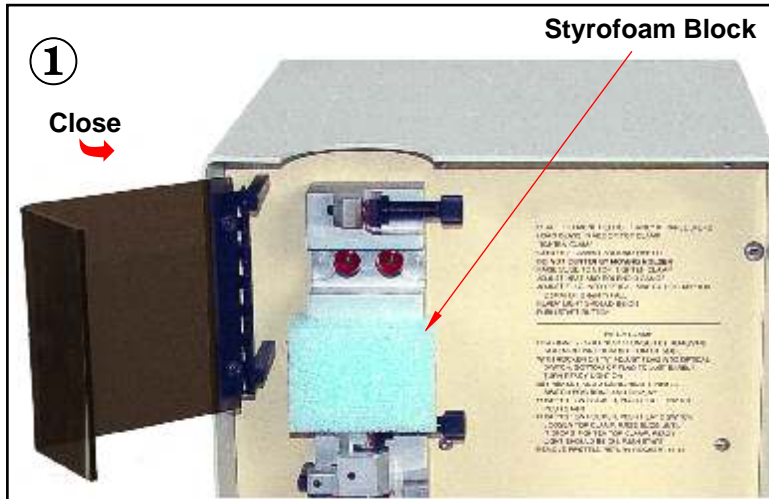

1. Place styrofoam block above slide mechanism to secure Solenoid and Plunger Assembly in place to prevent unit from sliding up and down during transit. Puller faceplate should be positioned over styrofoam block.

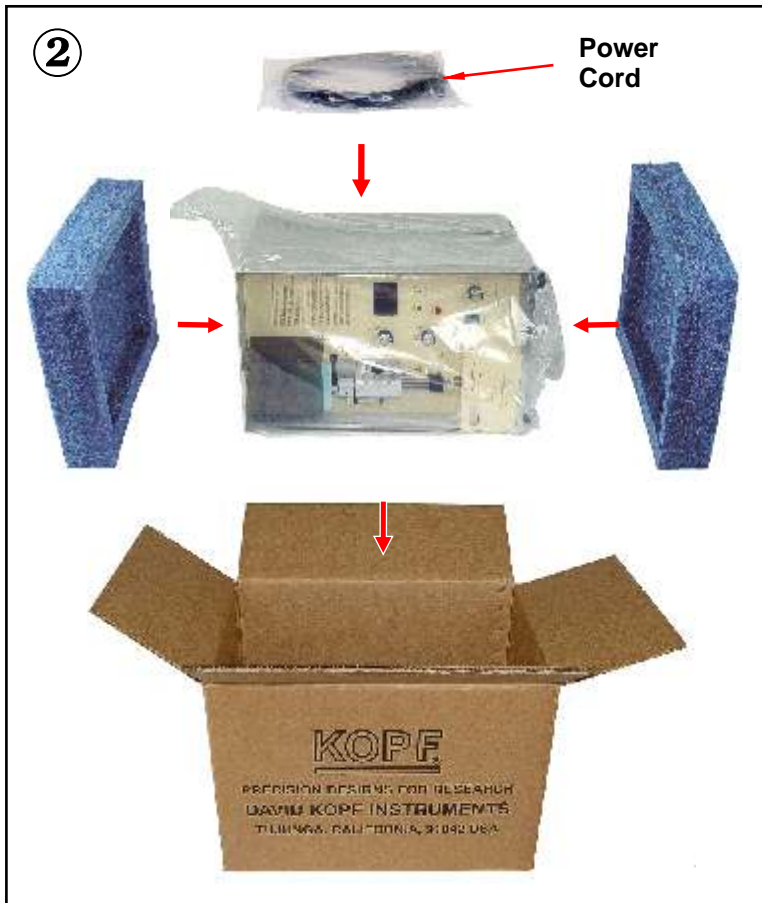

2. Place the Puller unit in a plastic bag on its side facing you. Place left and right side foam inserts on top and bottom of puller, the fit should be snug.

Place unit with foam inserts (facing you) into the original shipping box/carton.

Roll Power Cord and place into a bag and place on top of the Puller unit.

## ***Returned Goods***

**To apply for credit or exchange, goods must be received **WITHIN 30 DAYS** of shipment and certified to be new and unused.** All shipping cost and a 25% restocking fee may be charged. All items must be carefully packed in the manner in which they were originally shipped. Any damage costs incurred in their return will be charged to the customer. **Special items and custom designed items will not be accepted for return or credit.**

When returning, contact David Kopf Instruments for authorization. Please include your order number and our order number on all returns and correspondence. Ship parcels prepaid. We are unable to accept C.O.D. shipments.

## ***Important Notice for Returned Goods***

Due to increasing possibility of pathogenic contamination carried by instruments used in animal research procedures, **IT IS IMPERATIVE THAT ALL INSTRUMENTS returned to David Kopf Instruments, for any reason, be cleaned prior to shipment.**

It must be the responsibility of the user to properly clean all instruments prior to returning them to Kopf for any reason. We ask that all loose glass particles be removed carefully from unit. This policy is necessary to protect technicians and staff who work with returned instruments and to ensure their safety and health.

## ***Warranty and Disclaimer***

All product components manufactured by David Kopf Instruments are warranted to be free of defects in materials and workmanship for one year from date of shipment. Other manufacturer's products used are subject to their warranty.

There are no express warranties except as listed above. Additionally, such warranty becomes null and void because of abuse, disassembly, or unauthorized repair of product. Refer to the maintenance section of our catalog. All express and implied warranties, including the warranties of merchantability and fitness for a particular purpose, are limited to the applicable warranty period set forth above.

Each and every product designed, manufactured, and sold by David Kopf Instruments is intended exclusively for use in animal research and is not under any circumstances intended for use on humans or clinical practice on privately owned animals. Because our products are intended exclusively for use in animal research, none of the products designed, manufactured, or sold by David Kopf Instruments have been approved for use on humans by the Federal Drug Administration or any other federal or state agency. It has always been our position that our products are to be used exclusively in animal research. Any use of our products, except as provided in this paragraph, shall immediately terminate any warranty that might otherwise apply.

Warranties will be honored only on products purchased directly through our Tujung office or authorized David Kopf Instruments representatives.

***Notes:***

**David Kopf Instruments**

7324 Elmo Street  
Tujunga, CA 91042  
P.O. Box 636, Tujunga, CA 91043

E-mail: [sales@kopfinstruments.net](mailto:sales@kopfinstruments.net)  
[www.kopfinstruments.com](http://www.kopfinstruments.com)

Tel: 818.352.3274  
Fax: 818.352.3139  
Toll Free: 1.877.352.3275